

**DRAWING,
STRAIGHTENING
& CUT-OFF MACHINES**

Produce cut-to-length straight blanks or straight bars from hot rolled steel coils.

Capacity: Makes blanks & bar stock for diameters from 1/2" through 1 1/2"

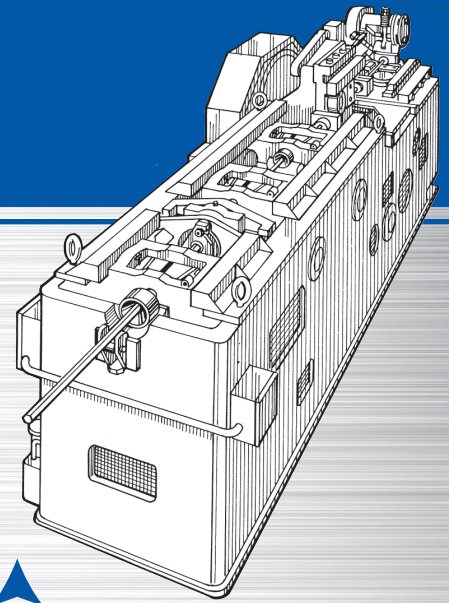

BAR DRAWERS

For sizing of hot rolled bars to accurate cold drawn dimensions – hex, round, or other shapes.

Current capacities up to 2" in diameter.

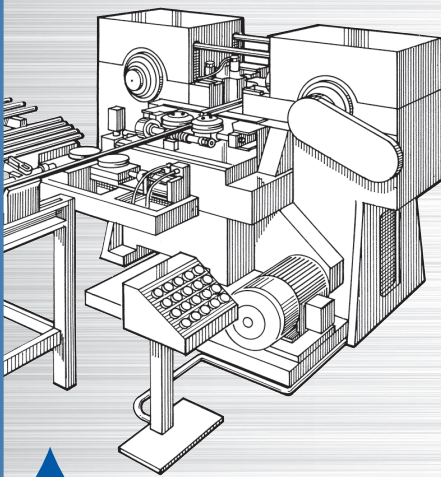

INSTACUT

Independent cut-off machine produces volume controlled slugs if less than one to one ratio (length to diameter.) INSTACUT machines can be coupled with standard Ajax wire drawers for conversion from hot rolled coiled (rod) stock to slugs.

Capacity: Diameters up to 1 1/2" with square cut ends.

CAPACITIES			
WIRE DRAWER SIZES	USUAL ALLOY BOLT STEELS	LOW CARBON STEEL-NORMAL DRAFTING	STANDARD DIE SLIDE BORE FOR DRAWING DIE
No. 0	1/4"	9/32"	2" dia.
No. 1	3/8"	7/16"	2" dia.
No. 2	1/2"	9/16"	3" dia.
No. 3	5/8"	1 1/16"	3" dia.
No. 4	3/4"	13/16"	4" dia.
No. 5	1"	1 1/16"	4" dia.
No. 6	1 1/4"	1 5/16"	6" dia.
No. 7	1 1/2"	1 9/16"	6" dia.
No. 8	2"	2 1/8"	7" dia.

IN-LINE DRAWING & CUT-OFF MACHINES

Draws hot rolled coiled stock for producing smaller diameter blanks.

Capacity: Diameters from 1/4" to 5/8"

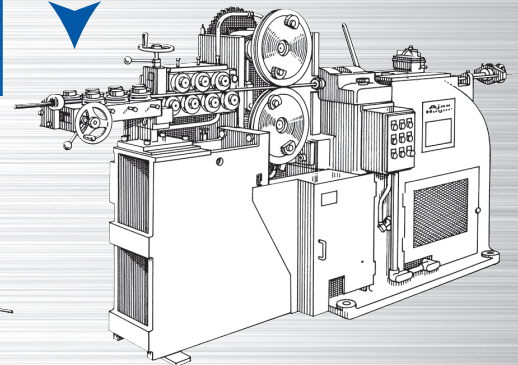

IN-LINE WIRE DRAWERS

For in-line drawing of all currently available hot rolled coiled stock. Used as attachments to headers, presses and shears.

Capacity: From 3/8" through 2" diameters



The Leader in Forging Since 1875

HOT, WARM AND COLD FORGING MACHINERY