

ADJUSTMENT

When Brake is in "ON" position, as shown, with cam slide at back stroke, stop on Cam Brake Lever (104) should be about 1 1/4" (A) from bed and lower stop of Spring Brake Lever (105) should be from 1/4" to 1/2" (B) from abutment on bed. If distance (A) is less, increase leather packing (L).

Adjustment of brake band by means of Brake Adjusting Strap (106) determines distance (B) but must not be changed as long as distance (B) is between 1/4" and 1/2". When less than 1/4" from wear of Brake Lining (102), ADJUST.

Brake Spring (109) should be adjusted to stop machine on back stroke. If it must be set so tight that Air Cylinder (111) with normal air pressure cannot completely release brake, CHECK THE CLUTCH to see that it is releasing promptly.

REVERSE BRAKE BAND when lining is worn half thru near cam lever end and the life will be doubled. If braking is irregular, clean lining and drum with Non-Flammable Detergent. To prevent scoring drum use only BRASS rivets in Brake Lining (102) and never let Steel Brake Band (103) contact drum. The brake lining used will stand 500°F. temperature but if this hot, INVESTIGATE.

TO "INCH" MACHINE WITH FOOT PEDAL

1. Set the stop on the clutch timer so the latch becomes inoperative.
2. Place the block (C) between the Cam Brake Lever (104) and the bed.
3. Operate the motor at reduced speed by joggling the control.
4. Engage the clutch intermittently by a quick treading motion.

TO BACK OFF MACHINE FROM STALL

1. Set stop on clutch timer so latch becomes inoperative.
2. Operate motor at full speed in reverse.
3. Engage clutch with full treadle stroke.
4. If machine does not respond, open pressure regulating valve to full line pressure TEMPORARILY.
5. If machine fails to respond drive down Toolholder Wedge, use jack, or crane on spanner wrench of Pinionshaft, or burn off the tool.

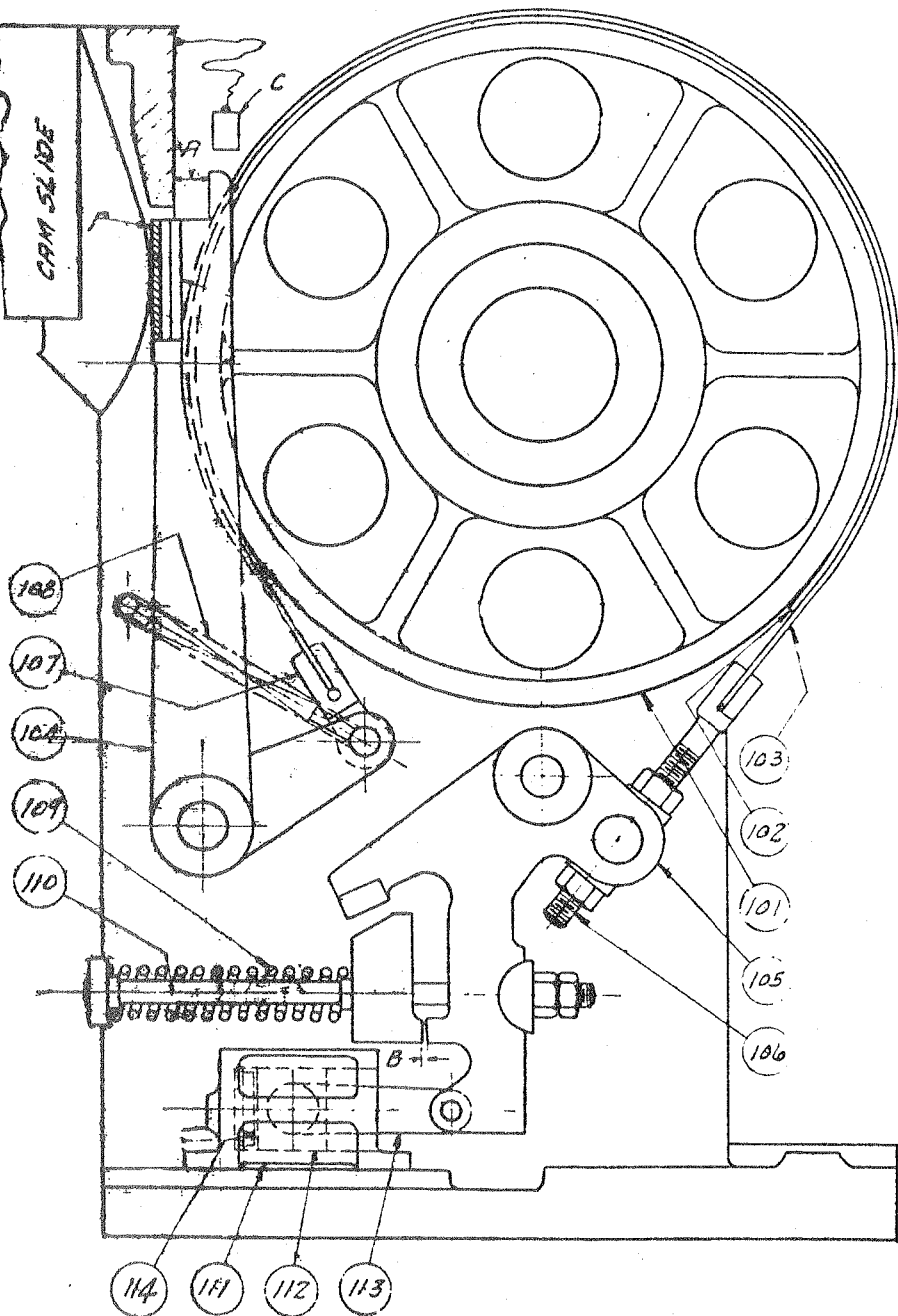

WHEN ORDERING REPLACEMENTS
STATE SERIAL NUMBER AND SIZE
STAMPED ON NAME PLATE OF
MACHINE AND DESIGNATE PART
BY BOTH NAME AND NUMBER.

- 101 BRAKE DRUM
- 102 BRAKE LINING & RIVETS
- 103 BRAKE BAND
- 104 CAM BRAKE LEVER
- 105 SPRING BRAKE LEVER
- 106 BRAKE ADJUSTING STRAP
- 107 BRAKE LINK
- 108 CAM BRAKE LEVER RETURN SPRING
- 109 BRAKE SPRING
- 110 BRAKE SPRING ADJ ROD
- 111 BRAKE RELEASE AIR CYLINDER
- 112 BRAKE REL. AIR CYLINDER PISTON
- 113 BRAKE CYL. CONNECTING LINK
- 114 BRAKE CYL. CUP PACKING