

When ordering replacements, state serial number and size stamped on name plate of machine and designate part by both name and number.

- 301 HEADER SLIDE
- 302 TOOLHOLDER CLAMP
- 303 TOOLHOLDER WEDGE
- 304 PITMAN
- 305 PITMAN CAP
- 306 PITMAN BOLTS
- 307 PITMAN BUSHING
- 308 PITMAN THRUST BUSHING
- 309 PITMAN WRIST PIN
- 310 PITMAN WRIST PIN BUSHINGS
- 311 HEADER SLIDE STATIONARY SIDE LINER
- 312 HEADER SLIDE ADJUSTING SIDE LINER
- 315 HEADER SLIDE RIGHT HAND LIP LINER
- 316 HEADER SLIDE LEFT HAND LIP LINER
- 317 BED LINER FOR HEADER SLIDE RIGHT LIP
- 318 BED LINER FOR HEADER SLIDE LEFT LIP
- 319 HEADER SLIDE EXTENSION TOP LINERS
- 320 HEADER SLIDE EXTENSION SIDE LINERS

- 321 HEADER SLIDE EXTENSION BOTTOM LINERS
- 322 HEADER AND CAM SLIDE COVER PLATE
- 323 HEADER SLIDE RIGHT HAND COVER PLATE
- 342 TOOLHOLDER KEY
- 343 TOOLHOLDER BOTTOM LINER

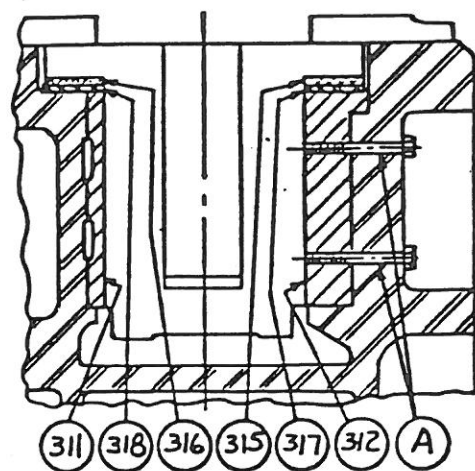

TO DISASSEMBLE HEADER SLIDE FROM BED

1. REMOVE PITMAN CAP (305).
2. REMOVE HEADER SLIDE COVER PLATES (322) AND (323).
3. REMOVE HEADER SLIDE EXTENSION BOTTOM LINERS (321).
4. REMOVE TOOLHOLDER
5. MOVE HEADER SLIDE (301) FORWARD AND UPWARD USING EYEBOLT IN TAPPED HOLE "B". THE HEADER SLIDE MUST BE GUIDED TO KEEP THE EXTENSION CLEAR OF THE CRANKSHAFT (201) AND BED FRAME RIBS.

ADJUSTMENT FOR SIDE WEAR

1. DISASSEMBLE THE HEADER SLIDE (301) FROM THE BED.
2. CLEAN UP THE HEADER SLIDE VERTICAL SURFACES.
3. CLEAN UP THE HEADER SLIDE SIDE LINERS (311) AND (312).
4. INSTALL AND CENTER THE HEADERSLIDE AND PITMAN (304).
5. MEASURE SPACES BETWEEN BED FRAME AND BOTH SIDES OF THE HEADER SLIDE. MEASURE THE WIDTH OF THE HEADER SLIDE AND ALLOW .001 INCHES PER INCH FOR RUNNING CLEARNACE. SHIM THE LINERS (311) AND (312) TO EQUALIZE THE CLEARANCE ON BOTH SIDES OF THE HEADER SLIDE.
6. RE-INSTALL HEADER SLIDE SIDE LINERS AND SHIMS, HEADER SLIDE, HEADER SLIDE EXTENSION BOTTOM LINERS (321), HEADER SLIDE COVER PLATES (322) AND (323), AND PITMAN CAP (305).

ADJUSTMENT FOR VERTICAL WEAR

1. REMOVE THE SHIMS FROM UNDER THE COVER PLATES (322) AND (323), AND IF NECESSARY REMOVE THE SHIMS FROM THE CAM SLIDE LINER (454).
2. COMPENSATE FOR EXTENSION WEAR BY SHIMMING ABOVE THE EXTENSION TOP LINER (319) AND BELOW THE EXTENSION BOTTOM LINERS (321).