

IDLER SHAFT ASSEMBLY

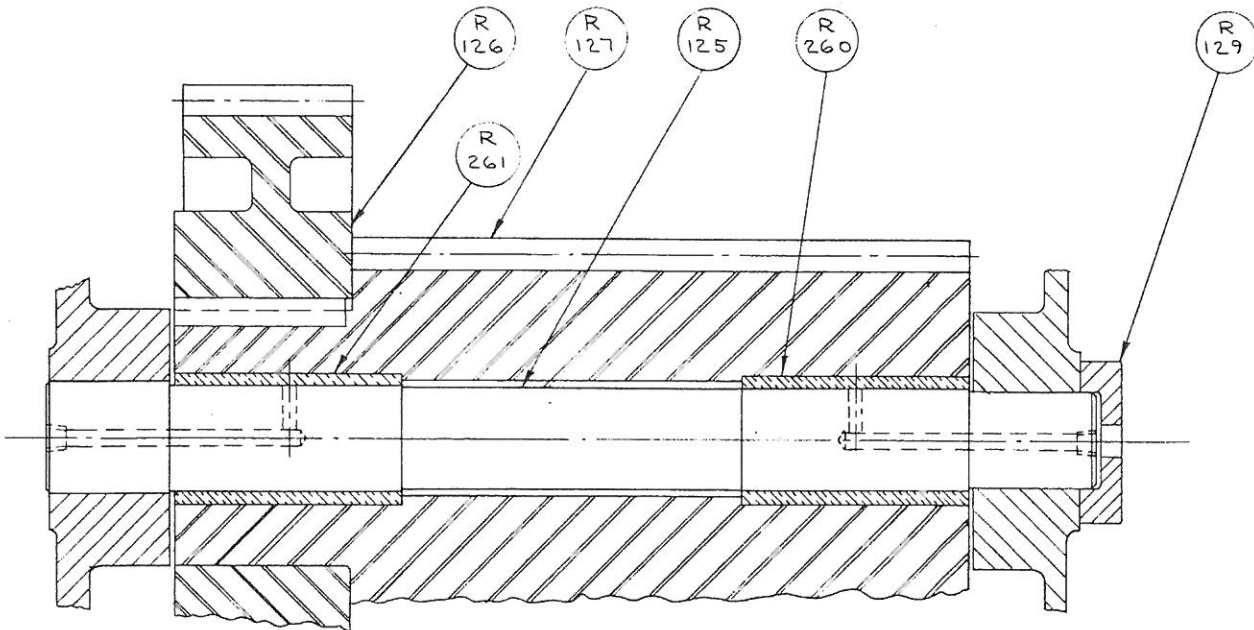

INTERMEDIATE SHAFT ASSEMBLY

WHEN ORDERING REPLACEMENTS
 STATE SERIAL NUMBER AND SIZE OF ROLL
 STAMPED ON NAME PLATE OF MACHINE
 AND DESIGNATE PART BY BOTH NAME
 AND NUMBER.

- R116 IDLER SHAFT
- R117 IDLER GEAR
- R120 IDLER SHAFT THRUST COLLAR
- R123 IDLER GEAR BUSHING
- R124 IDLER SHAFT END CAP

- R125 INTERMEDIATE SHAFT
- R126 INTERMEDIATE GEAR
- R127 INTERMEDIATE PINION
- R129 INTERMEDIATE SHAFT END CAP
- R260 INTERMEDIATE PINION BUSHING
- R261 INTERMEDIATE PINION BUSHING.