

DIE SLIDE PARTS LIST

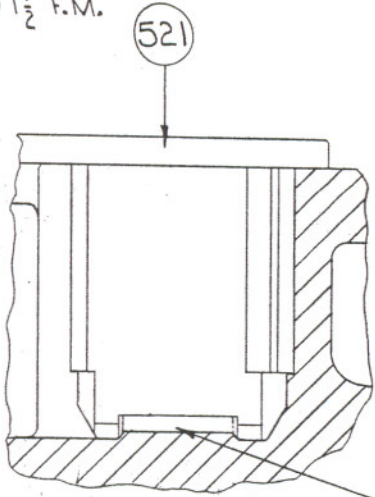

SHEET H-2
1" AND 1 1/2" F.M.



SECTION Y-Y

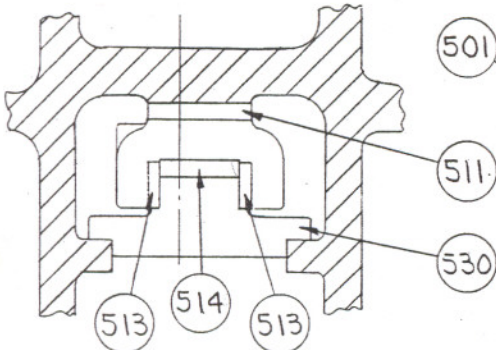
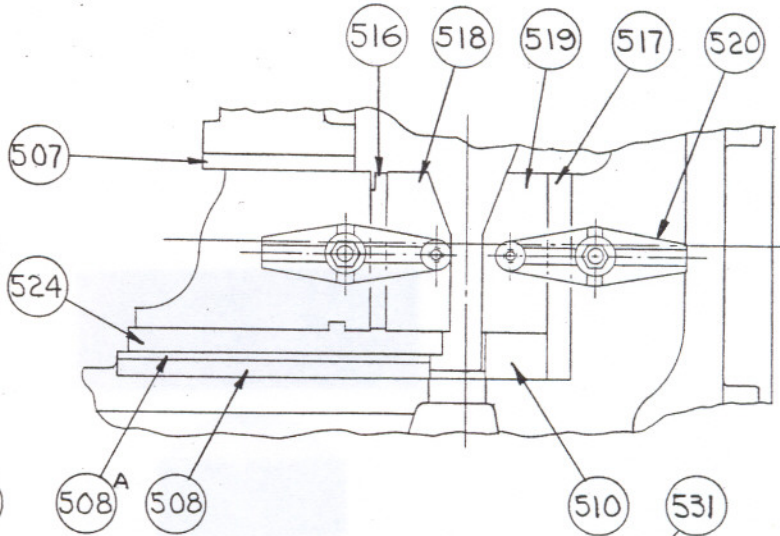

SECTION X-X

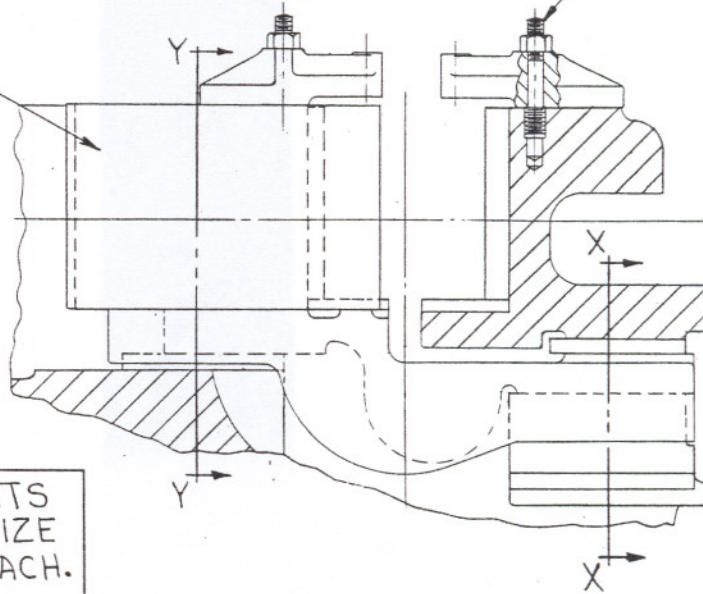

WHEN ORDERING REPLACEMENTS
STATE SERIAL NUMBER AND SIZE
STAMPED ON NAME PLATE OF MACH.
AND DESIGNATE PART BY BOTH
NAME AND NUMBER.

- 501 DIE SLIDE
- 507 DIE SLIDE SIDE LINER
- 508 MOVING DIE BACKING PLATE
- 508^A MOVING DIE BACKING PLATE LINER

- 510 STATIONARY DIE THRUST BLOCK
- 511 DIE SLIDE EXTENSION TOP LINER
- 513 DIE SLIDE EXTENSION SIDE LINERS
- 514 DIE SLIDE EXTENSION BOTTOM LINER

- 516 MOVING DIE SIDE LINER
- 517 STATIONARY DIE SIDE LINER
- 518 MOVING DIE BOTTOM LINER
- 519 STATIONARY DIE BOTTOM LINER
- 520 DIE CLAMPS
- 521 DIE SLIDE COVER PLATE
- 524 DIE SLIDE THRUST LINER
- 529 DIE SLIDE BOTTOM LINER
- 530 DIE SLIDE EXTENSION BLOCK
- 531 DIE CLAMP STUDS

THE AJAX MANUFACTURING CO.
CLEVELAND 17, OHIO