

# Ajax

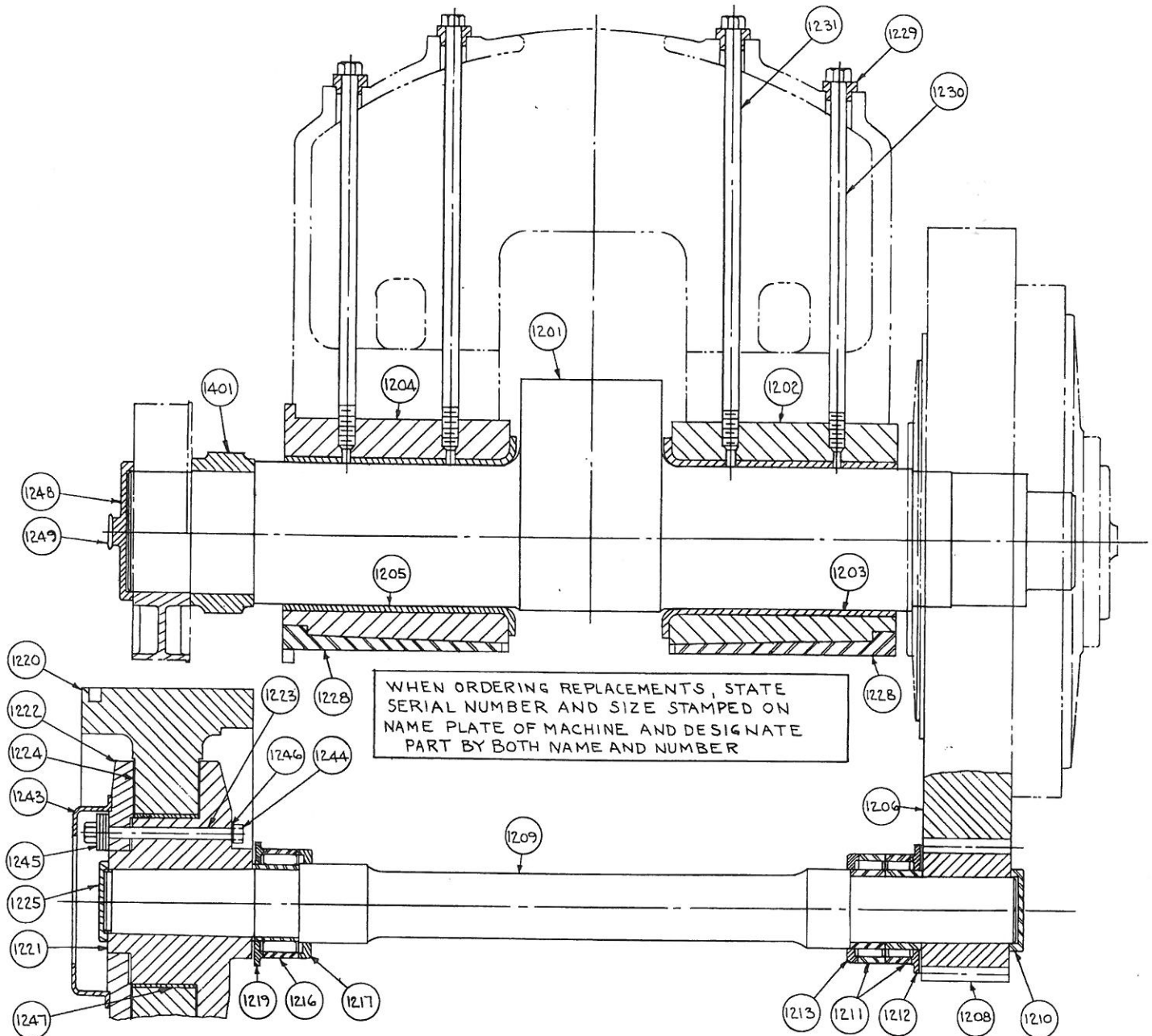

- 1201 CRANKSHAFT.
- 1202 CRANKSHAFT R.H. SLEEVE.
- 1203 CRANKSHAFT R.H. SLEEVE BUSHING.
- 1204 CRANKSHAFT L.H. SLEEVE.
- 1205 CRANKSHAFT L.H. SLEEVE BUSHING.
- 1206 MAIN GEAR.
- 1208 MAIN PINION.
- 1209 PINION SHAFT.
- 1210 MAIN PINION RETAINING PLATE.
- 1211 PINION SHAFT R.H. ROLLER BEARING. (S).
- 1212 PINION SHAFT R.H. BEARING END COLLAR.
- 1213 PINION SHAFT R.H. BEARING SEAL RING.
- 1216 PINION SHAFT L.H. ROLLER BEARING.
- 1217 PINION SHAFT L.H. BEARING SEAL RING.
- 1219 PINION SHAFT L.H. BEARING END COLLAR.
- 1220 FLYWHEEL RIM.
- 1221 FLYWHEEL HUB.
- 1222 FLYWHEEL CLAMP PLATE.
- 1223 FLYWHEEL CLAMP BOLTS.
- 1224 FLYWHEEL FRICTION PLATES.

- 1225 FLYWHEEL HUB RETAINING PLATE.
- 1228 ECCENTRIC SHAFT SLEEVE BOTTOM WEDGES.
- 1229 ECCENTRIC SHAFT SLEEVE BOLT WASHERS.
- 1230 ECCENTRIC SHAFT SLEEVE BOLTS (SHORT).
- 1231 ECCENTRIC SHAFT SLEEVE BOLTS (LONG).
- 1243 FLYWHEEL CLAMP BOLT GUARD.
- 1244 FLYWHEEL CLAMP BOLT NUTS.
- 1245 BELLVILLE WASHERS.
- 1246 FLYWHEEL CLAMP BOLT SHIMS.
- 1247 FLYWHEEL BUSHING.
- 1248 BRAKE DRUM RETAINING PLATE.
- 1249 TIMER DRIVING SPROCKET.
- 1401 BOTTOM KNOCKOUT CAM.