

# Ajax

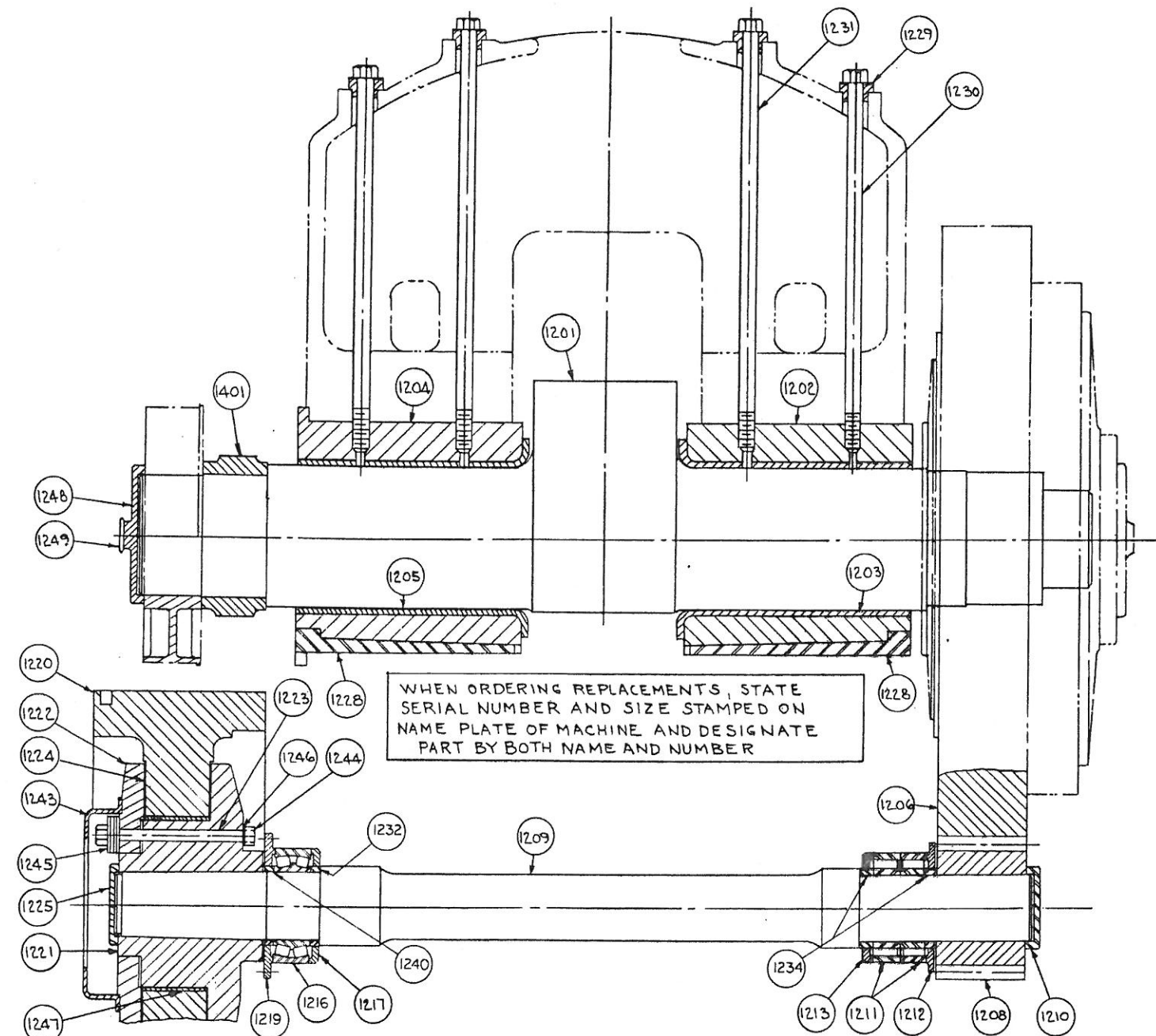

1201 CRANKSHAFT.  
 1202 CRANKSHAFT R.H. SLEEVE.  
 1203 CRANKSHAFT R.H. SLEEVE BUSHING.  
 1204 CRANKSHAFT L.H. SLEEVE.  
 1205 CRANKSHAFT L.H. SLEEVE BUSHING.  
 1206 MAIN GEAR.  
 1208 MAIN PINION.  
 1209 PINION SHAFT.  
 1210 MAIN PINION RETAINING PLATE.  
 1211 PINION SHAFT R.H. ROLLER BEARING. (S).  
 1212 PINION SHAFT R.H. BEARING RETAINING RING  
 1213 PINION SHAFT R.H. BEARING SPACER  
 1216 PINION SHAFT L.H. SPHERICAL BEARING.  
 1217 PINION SHAFT L.H. BEARING SPACER  
 1219 PINION SHAFT L.H. BEARING RETAINING RING  
 1220 FLYWHEEL RIM.  
 1221 FLYWHEEL HUB.  
 1222 FLYWHEEL CLAMP PLATE.  
 1223 FLYWHEEL CLAMP BOLTS.  
 1224 FLYWHEEL FRICTION PLATES.

1225 FLYWHEEL HUB RETAINING PLATE.  
 1228 ECCENTRIC SHAFT SLEEVE BOTTOM WEDGES.  
 1229 ECCENTRIC SHAFT SLEEVE BOLT WASHERS.  
 1230 ECCENTRIC SHAFT SLEEVE BOLTS (SHORT).  
 1231 ECCENTRIC SHAFT SLEEVE BOLTS (LONG).  
 1232 BEARING SPACER  
 1234 BEARING SPACER  
 1240 BEARING SPACER  
 1243 FLYWHEEL CLAMP BOLT GUARD  
 1244 FLYWHEEL CLAMP BOLT NUTS  
 1245 BELLVILLE WASHERS  
 1246 FLYWHEEL CLAMP BOLT SHIMS  
 1247 FLYWHEEL BUSHING  
 1248 BRAKE DRUM RETAINING PLATE  
 1249 TIMER DRIVING SPROCKET  
 1401 BOTTOM KNOCKOUT CAM

# Ajax

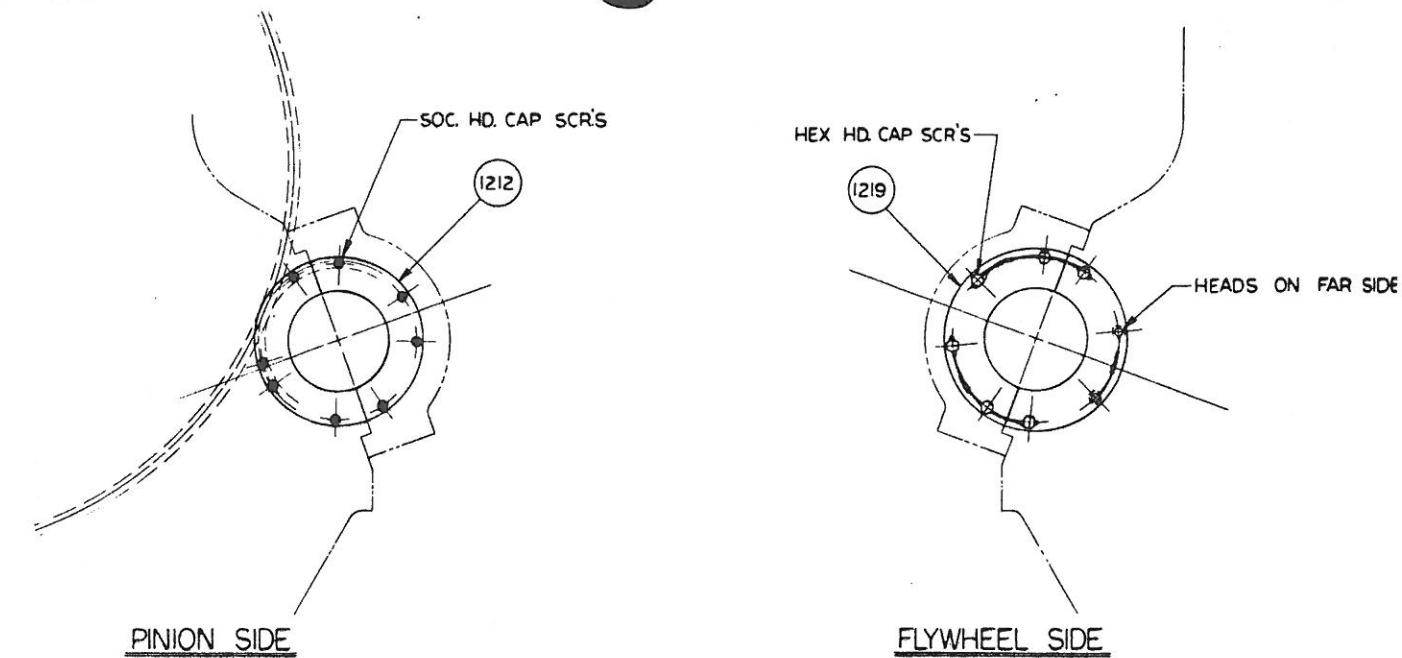

### INSTRUCTION FOR REMOVING PINION SHAFT

PINION SHAFT ASSEMBLY INCLUDING FLYWHEEL AND PINION GEAR CAN BE REMOVED FROM PRESS AS FOLLOWS:

- 1--REMOVE SAFETY WIRES FROM HEX. HD. CAP SCREWS HOLDING BRG. RETAINERS AT FLYWHEEL SIDE OF PRESS AND BACK OFF SCREWS TWO(2) COMPLETE REVOLUTIONS.
- 2--ALIGN PINION GEAR WITH SOCKET HD. CAP SCREWS SO THAT CAP SCREWS ARE IN SPACES BETWEEN GEAR TEETH AND BACK OFF BEARING RETAINER SCREWS 1½ TO 2 COMPLETE REVOLUTIONS.  
 WARNING!! IF SCREWS ARE BACKED OFF MORE THAN 3 COMPLETE REVOLUTIONS THEY WILL BE DAMAGED DURING PINION SHAFT REMOVAL.
- 3--PULL BEARING CAP DOWELS AND REMOVE BEARING CAP HOLD DOWN NUTS. REMOVE BEARING CAPS. TOP HALF OF BEARING RETAINERS COME ALONG WITH CAPS.
- 4--REMOVE PINION SHAFT FROM PRESS MAINTAINING A PARALLEL RELATIONSHIP BETWEEN IT AND CENTER LINE OF ECCENTRIC SHAFT.

FOR ASSEMBLY REVERSE THE ABOVE PROCEDURE