

Ajax

Ajax

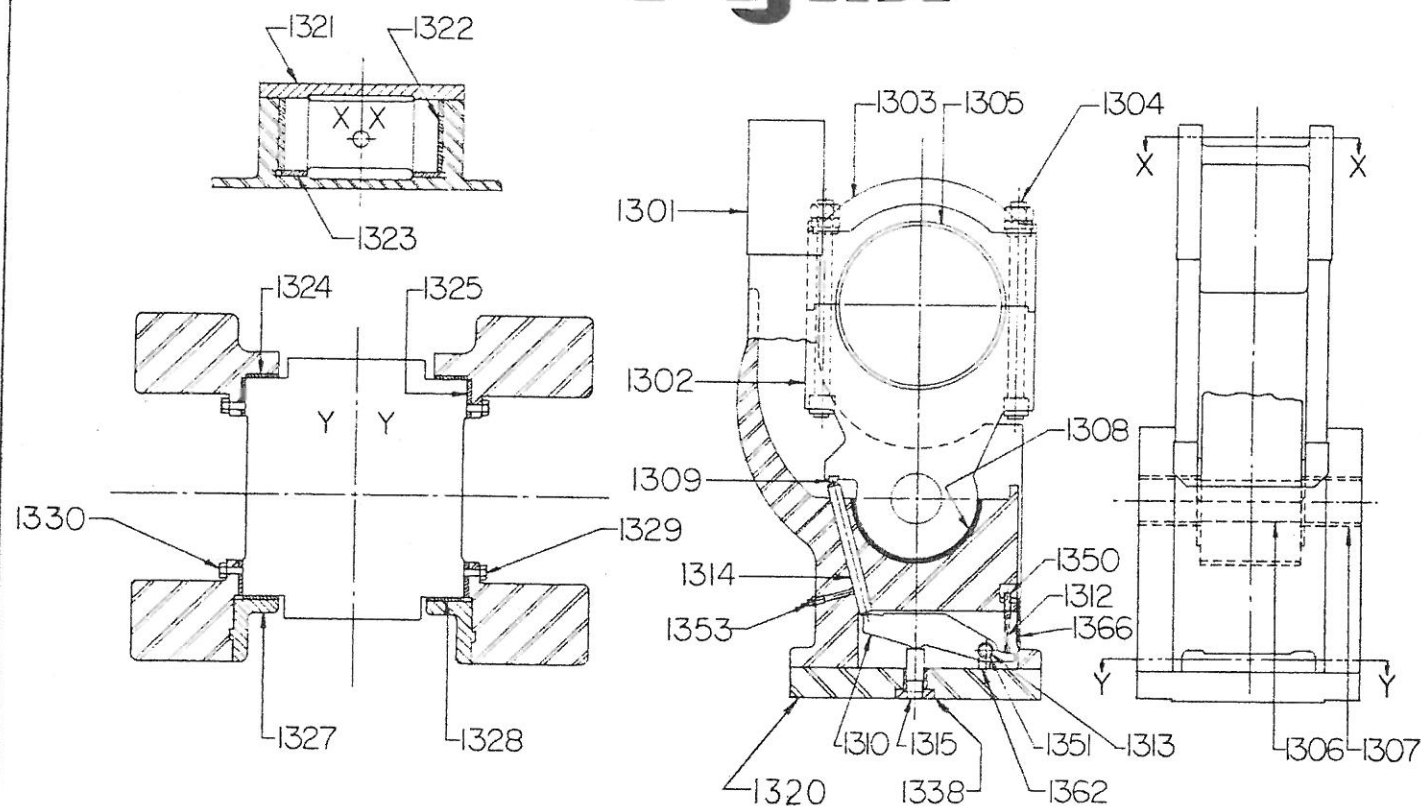

WHEN ORDERING REPLACEMENTS, STATE SERIAL NUMBER AND SIZE STAMPED ON NAME PLATE OF MACHINE AND DESIGNATE PART BY BOTH NAME AND NUMBER

1301 RAM	1321 RAM EXTENSION COVER PLATE
1302 PITMAN	1322 RAM EXTENSION SIDE LINERS
1303 PITMAN CAP	1323 RAM EXTENSION REAR LINERS
1304 PITMAN BOLTS	1324 FRAME REAR LINERS
1305 PITMAN AND CRANKSHAFT BUSHING	1325 FRAME SIDE LINERS
1306 PITMAN WRIST PIN	1327 FRONT GIBS-RIGHT AND LEFT HAND
1307 PITMAN WRIST PIN BUSHINGS	1328 FRONT GIB LINERS
1308 RAM THRUST BUSHING	1329 RIGHT SIDE LINER SCREWS
1309 PITMAN KICKER LUG INSERT	1330 LEFT SIDE LINER SCREWS
1310 UPPER KNOCKOUT LEVER	1338 KICKER PIN RETAINER
1312 UPPER KNOCKOUT SPRING	1350 UPPER KNOCKOUT SPRING ADJUSTER
1313 UPPER KNOCKOUT LEVER FULCRUM PIN	1351 LEVER BUSHING
1314 UPPER KNOCKOUT DRIVE PIN	1353 DRIVE PIN RETAINER
1315 UPPER KNOCKOUT KICKER PIN	1362 SPACER BLOCK
1320 RAM PLATE	1366 SPRING GUARD

ADJUSTMENT FOR SIDE WEAR

1. REMOVE GIBS (1327).
2. LOOSEN SCREWS (1329 & 1330) IN SIDE OF PRESS FRAME AND REMOVE LINERS (1325).
3. INSTALL SUITABLE SHIMS TO FIT BETWEEN THE LINER (1325) AND BED ALLOWING APPROX. .0006" PER INCH OF RAM WIDTH FOR RUNNING CLEARANCE AND REPLACE LINERS REVERSING THE ABOVE PROCEDURE.

ADJUSTMENT FOR FRONT TO BACK WEAR

4. REMOVE LINERS (1328) AND INSTALL SUITABLE SHIMS BETWEEN THEM AND FRONT GIBS (1327). ALSO REMOVE LINERS 1324 AND INSTALL SUITABLE SHIMS BETWEEN THEM AND FRAME. ALLOW OPERATING CLEARANCE OF APPROX. .0006" PER INCH OF RAM WIDTH.
5. TO COMPENSATE FOR FRONT TO BACK WEAR ON BEARING OF THE RAM EXTENSION, LINERS (1323) MAY BE REMOVED, AND SUITABLE SHIMS INSTALLED BETWEEN THEM AND THE FRAME, AND IF NECESSARY, REMOVE SHIMS OF THE PROPER THICKNESS FROM UNDER THE EXTENSION COVER PLATE (1321).

UPPER KNOCKOUT ADJUSTMENT

6. UPPER KNOCKOUT HAS BEEN SET FOR MAXIMUM STROKE OF KICKER PIN (1315). TO REDUCE THIS STROKE, THE KICKER PIN SHOULD BE REMOVED FROM THE RAM AND THE BOTTOM OF THE PIN CUT OFF TO SUIT THE REQUIRED STROKE.

CAUTION

NEVER INCREASE KICK BEYOND MAXIMUM STROKE (PER TOOL & DIE SPACE) SINCE THAT WILL CAUSE FAILURE IN UPPER KNOCKOUT MECHANISM.