

ONE PAIR OF CAMS IN THE ROTARY CAM SWITCH CONTROLS THE ELECTRIC TIMER. THE VERTICALLY UP POSITION OF THE ZERO MARK ON THE TIMING DIAL REPRESENTS THE RAM TOP DEAD CENTER POSITION. FOR INITIAL SETTING OF THE BOTTOM KNOCKOUT TIMING, ROTATE THE 180 DEGREE MARK TO TOP POSITION, LOOSEN THE OUTER CAM AND ROTATE IT CLOCKWISE UNTIL THE CONTACT JUST CLOSURES. TIGHTEN THE OUTER CAM, ROTATE THE 270 DEGREE MARK TO TOP POSITION, LOOSEN THE INNER CAM AND ROTATE IT COUNTER-CLOCKWISE UNTIL THE CONTACT JUST OPENS. TIGHTEN THE INNER CAM. TO ADVANCE TIMING, LOOSEN BOTH CAMS AND ROTATE THEM EQUAL AMOUNTS IN A CLOCKWISE DIRECTION. TIGHTEN BOTH CAMS. TO DELAY TIMING, ROTATE BOTH CAMS EQUAL AMOUNTS IN A COUNTER-CLOCKWISE DIRECTION. TIGHTEN BOTH CAMS.

THE ELECTRIC TIMER HAS A MINIMUM TIME DWELL SETTING OF ONE SECOND AND TIME DIVISIONS OF ONE-HALF SECOND. WHEN THE TIMER IS ENERGIZED BY THE ROTARY CAM SWITCH, IT ENERGIZES THE MAIN AIR VALVE WHICH OPENS AND PASSES AIR TO THE CYLINDER. ITS ROD EXTENDS TO SUPPORT THE BOTTOM KNOCKOUT CYLINDER SHUTTLE (1534) AGAINST THE STOP SCREW (1531), HOLDING THE BOTTOM KNOCKOUT BELLCRANK AT MAXIMUM KICK POSITION. AFTER THE SELECTED TIME DELAY, THE TIMER DE-ENERGIZES THE MAIN AIR VALVE WHICH EXHAUSTS THE CYLINDER AIR, ITS ROD RETRACTS BY GRAVITY. A DETENTED PUSHBUTTON CAN BE PUSHED IN TO LOCK OUT THE TIMER AND TO ENERGIZE DIRECTLY THE MAIN AIR VALVE. TO DE-ENERGIZE THE MAIN AIR VALVE AND TO RELEASE THE BELLCRANK, THE PUSHBUTTON IS PULLED OUT TO A SECOND DETENTED POSITION.

- KICKER PIN STROKE ADJUSTMENT
1. BACK OUT STOP SCREW (1531).
 2. REFER TO BOTTOM KNOCKOUT INSTRUCTION SHEET AND ADJUST MECHANICAL STROKE.
 3. INCH PRESS TO POSITION BOTTOM KNOCKOUT AT MAXIMUM KICK.
 4. TURN STOP SCREW (1531) IN UNTIL IT JUST CONTACTS BOTTOM KNOCKOUT CYLINDER SHUTTLE.

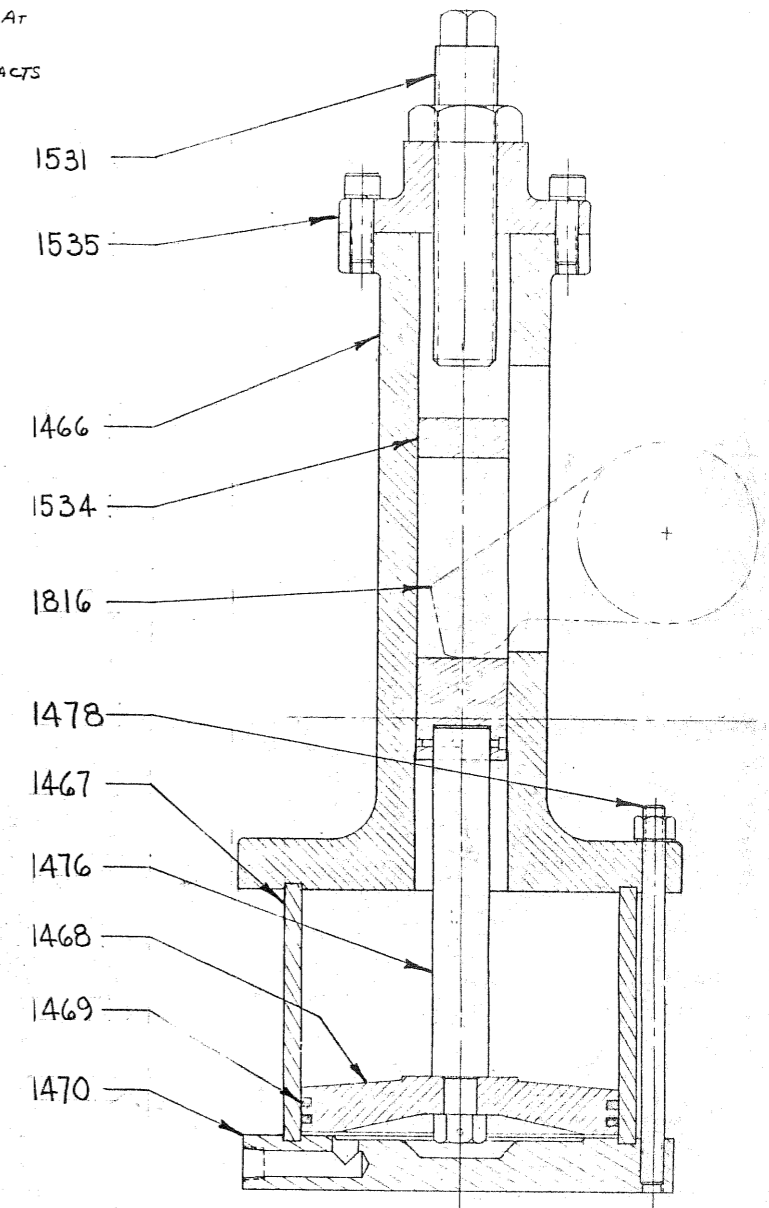

WHEN ORDERING REPLACEMENTS, STATE SERIAL NUMBER AND SIZE STAMPED ON NAMEPLATE OF MACHINE AND DESIGNATE PART BY BOTH NAME AND NUMBER

- | | |
|---------------------------|---|
| 1466 TOP CYLINDER HEAD | 1478 STUDS |
| 1467 AIR CYLINDER | 1816 BELLCRANK |
| 1468 PISTON | 1531 BOTTOM K.O. OPER. LEVER STOP SCREW |
| 1469 PISTON RINGS | 1534 SHUTTLE |
| 1470 BOTTOM CYLINDER HEAD | 1535 GUIDE HOUSING CAP |
| 1476 PISTON ROD | |