

GRIP BOX
PARTS LIST

A J A X

SHEET WD-5-B

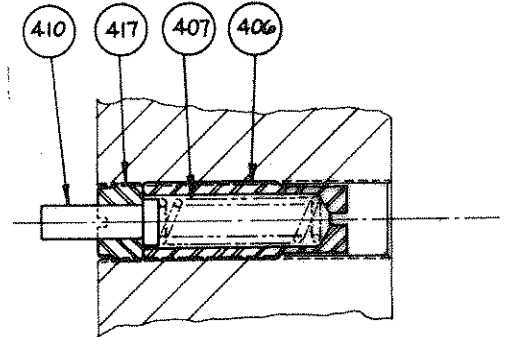
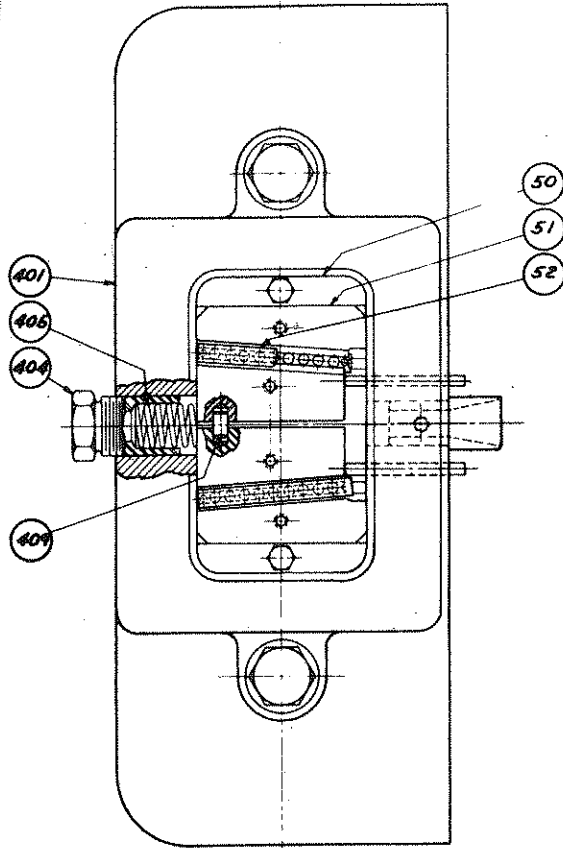

SECTION AA

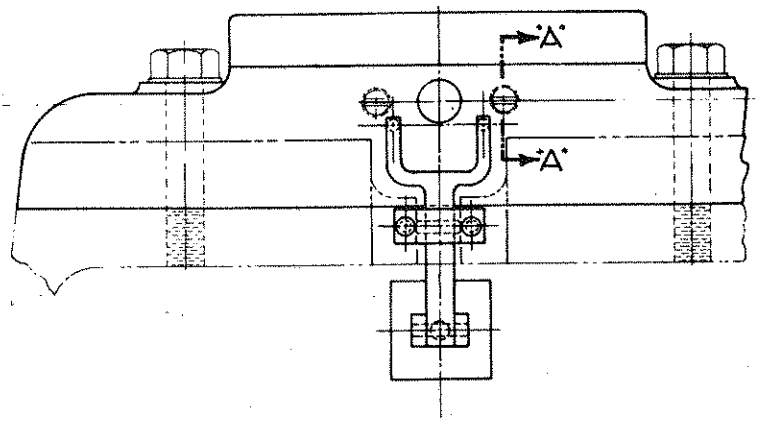
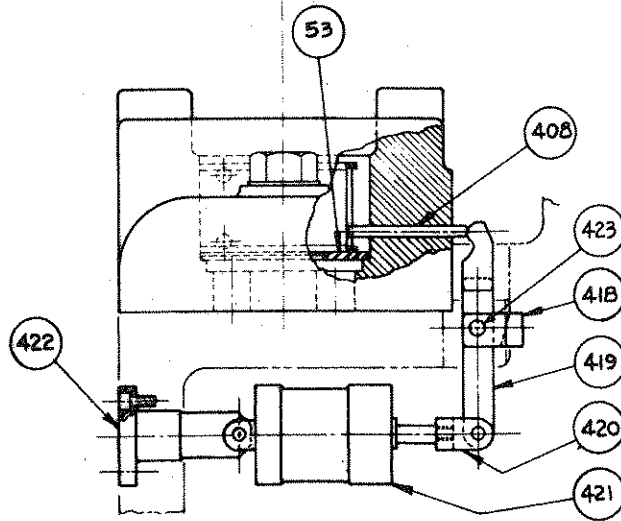

400 GRIP BOX COMPLETE WITH PARTS LISTED BELOW

- | | |
|---|---------------------------------------|
| 401 GRIP BOX | 419 GRIP RELEASE LEVER |
| 404 HOLLOW SCREW FOR GRIP BOX | 420 CYLINDER CLEVIS FOR RELEASE LEVER |
| 405 SPRING FOR GRIP BOX HOLLOW SCREW | 421 AIR CYLINDER |
| 406 SCREWS FOR ROLLER CAGE ACTUATING SPRING | 422 AIR CYLINDER MOUNTING LUG |
| 407 ROLLER CAGE ACTUATING SPRINGS | 423 FULCRUM PIN FOR RELEASE LVR. |
| 408 PINS FOR GRIP BLOCK RELEASE | |
| 409 PINS FOR GRIP BLOCKS | 50 BACKING BLOCKS FOR GRIP |
| 410 PLUGS FOR ROLLER CAGE SPRINGS | 51 STATIONARY WEDGE BLOCKS FOR GRIP |
| 417 LOCK SCREW FOR PLUGS | 52 ROLLER CAGES |
| 418 RELEASE LEVER FULCRUM BLOCK | 53 BOTTOM LINER FOR GRIP BOX |

WHEN ORDERING REPLACEMENT PARTS STATE SERIAL NUMBER AND SIZE STAMPED ON NAMEPLATE OF MACHINE AND DESIGNATE PART BY BOTH NAME AND NUMBER.

THE AJAX MANUFACTURING COMPANY, CLEVELAND OHIO, 44117