

GRIP BOX
PARTS LIST
SHEET WD-5-D

Ajax

400 GRIP BOX COMPLETE WITH ALL PARTS LISTED BELOW

- 401 GRIP BOX
- 404 HOLLOW SCREW FOR GRIP BOX
- 405 SPRING FOR HOLLOW SCREW
- 407 ROLLER CAGE ACTUATING SPRING (2 REQ'D.)
- 408 PINS FOR GRIP BLOCK RELEASE (2 REQ'D.)
- 409 PINS FOR GRIP BLOCKS (SPRING PINS) (2 REQ'D.)
- 410 PLUGS FOR ROLLER CAGE SPRINGS (2 REQ'D.)
- 419 GRIP RELEASE LEVER
- 421 AIR CYLINDER
- 423 FULCRUM PIN FOR RELEASE LEVER
- 424 SPRING RETAINER (PIPE PLUGS) (2 REQ'D.)
- 425 BRACKET FOR RELEASE LEVER
- 426 PLUG FOR CYLINDER ROD END

- 50 BACKING BLOCKS FOR GRIP (ORDER IN PAIRS)
- 51 STATIONARY WEDGE BLOCKS FOR GRIP (ORDER IN PAIRS)
- 52 ROLLER CAGES (ORDER IN PAIRS)
- 53 BOTTOM LINER FOR BOX

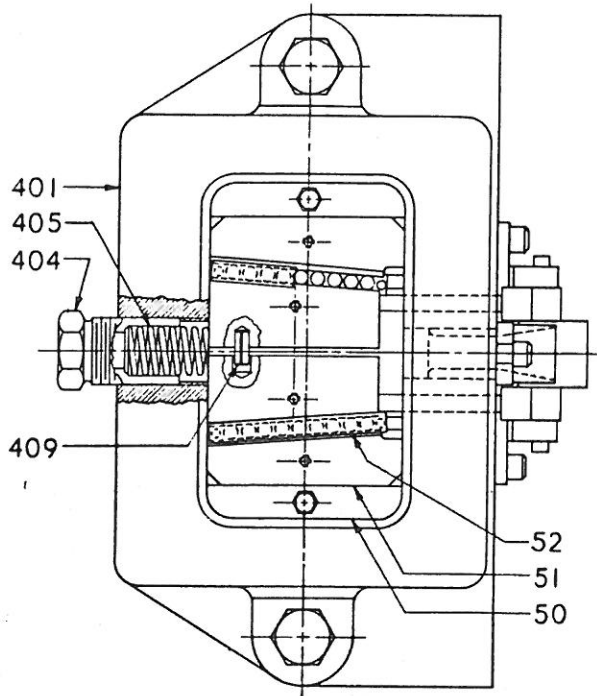

WHEN ORDERING REPLACEMENT PARTS,
STATE SERIAL NUMBER AND SIZE STAMPED
ON NAME PLATE OF MACHINE AND DESIGNATE
PART BY BOTH NAME AND NUMBER.

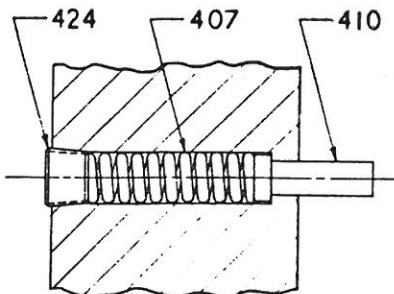
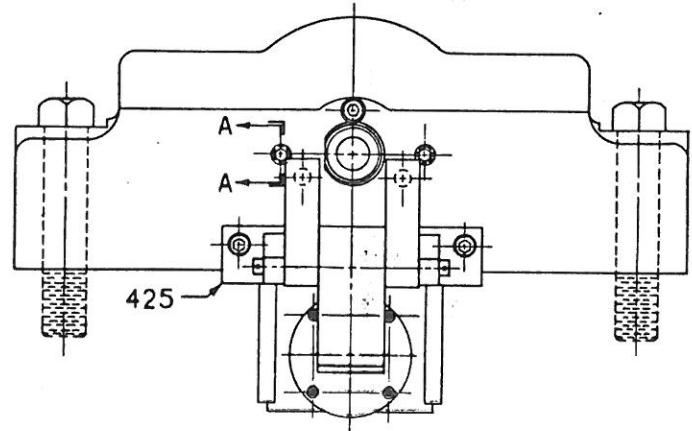
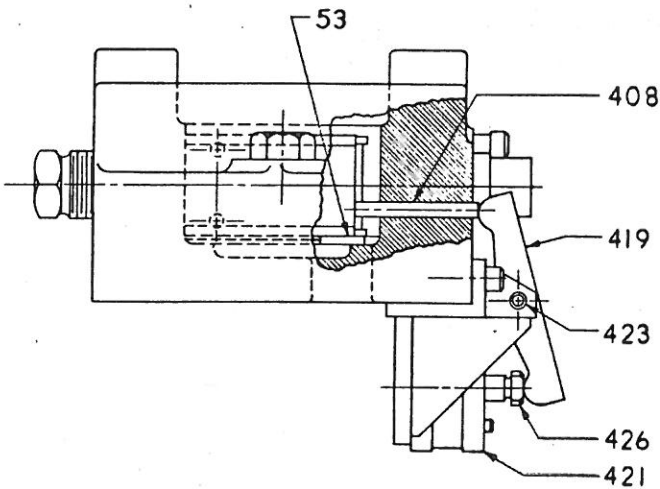

SECTION A-A

GRIP BOX
PARTS LIST
SHEET WD-5-D